



# Zero-Carbon Home Heating in China's Yangtze River Delta Region

## Heat Pumps as a Core Solution





## About RMI

RMI is an independent nonprofit founded in 1982 that transforms global energy systems through market-driven solutions to align with a 1.5°C future and secure a clean, prosperous, zero-carbon future for all. We work in the world's most critical geographies and engage businesses, policymakers, communities, and NGOs to identify and scale energy system interventions that will cut greenhouse gas emissions at least 50 percent by 2030. RMI has offices in Basalt and Boulder, Colorado; New York City; Oakland, California; Washington, D.C.; and in Beijing, People's Republic of China.

# Authors and Acknowledgments

## Authors

Yihan Hao  
Xinxin Hu  
Ting Li  
Guangxu Wang  
Meng Wang

## Other Contributors

Edward Chen, formerly from RMI  
Nianying Wu

Authors listed alphabetically. All authors from RMI unless otherwise noted.

## Contacts

Meng Wang, [mwang@rmi.org](mailto:mwang@rmi.org)  
Guangxu Wang, [gwang@rmi.org](mailto:gwang@rmi.org)

## Copyrights and Citation

Yihan Hao, Xinxin Hu, Ting Li, Guangxu Wang, Meng Wang, *Zero-Carbon Home Heating in China's Yangtze River Delta Region: Heat Pumps as a Core Solution*, RMI, 2023, <https://rmi.org/insight/zero-carbon-home-heating-in-chinas-yangtze-river-delta-region/>.

RMI values collaboration and aims to accelerate the energy transition through sharing knowledge and insights. We therefore allow interested parties to reference, share, and cite our work through the Creative Commons CC BY-SA 4.0 license. <https://creativecommons.org/licenses/by-sa/4.0/>.

All images used are from iStock.com unless otherwise noted.

## Acknowledgements

The authors thank the following individuals for offering their insights and perspectives. Appearing on this list does not indicate endorsement of the report's findings.

Brett Bridgeland, RMI  
Yifeng Gao, Heat Pump Committee at China Energy Conservation Association  
Stephanie Greene, RMI  
Wenxing Shi, School of Architecture, Tsinghua University

# Table of Contents

<b>Abbreviations</b>	5
<b>China’s Yangtze River Delta Region Urgently Needs Better and Zero-Carbon Heating</b>	6
<b>Challenges of Home Heating in the Yangtze River Delta Region</b>	9
Development Trends of Home Heating	9
<b>Comparative Analysis of Distributed Home Heating Systems in the Yangtze River Delta Region</b>	11
Major Distributed Home Heating Devices in the YRD Region	11
Multidimensional Comparison	14
Conclusions	23
<b>Zero-Carbon Pathway by Scaling Heat Pumps in the Yangtze River Delta Region</b>	23
<b>Major Challenges and Suggestions to Promote Heat Pumps in the YRD Region</b>	27
Major Challenges	27
Suggestions	28
<b>Heat Pumps for China and Beyond</b>	31
<b>Appendix A: Building Simulation Input Parameters</b>	33
<b>Appendix B: Concepts and Assumptions for Economic Analysis</b>	34
<b>Endnotes</b>	35

# Abbreviations

<b>ASHP</b>	Air source heat pump
<b>EFH</b>	Electric floor heating
<b>GSHP</b>	Ground source heat pump
<b>HPFH</b>	Heat pump hydronic floor heating
<b>Mini-splits</b>	Ductless, mini-split system air conditioners
<b>PERH</b>	Portable electric resistance heater
<b>WSHP</b>	Water source heat pump
<b>YRD</b>	Yangtze River Delta

# China's Yangtze River Delta Region Urgently Needs Better and Zero-Carbon Heating

Space heating improves people's quality of life, but it's also a major source of energy consumption and carbon emissions. In 2021, space heating and domestic hot water accounted for almost 15% of global final energy consumption, resulting in about 2.45 billion tons of CO<sub>2</sub> emissions. Given the growing global population and improving living standards, the heated building floor area is predicted to increase by 12% between 2021 and 2030.<sup>1</sup> Because the energy required for heating is provided mainly by fossil fuels such as natural gas, the increasing heated floor area will lead to a significant increase in the CO<sub>2</sub> emissions of the building sector, which poses a huge challenge to global climate targets.

In China, residents of the northern regions have district heating service provided by the government, but residents of southern China still have a significant lack of heating facilities. Climate change is causing frequent extreme weather.<sup>1</sup> These changes, coupled with the higher living standard resulting from rapid economic growth, mean that effective heating facilities for indoor environments during the winter in southern China are more urgently needed than ever. Under China's ambitious climate target, provinces have started to make plans to achieve their own carbon peaking and carbon neutrality goals. It is necessary to develop a customized zero-carbon heating pathway in the vast southern regions.

## Exhibit 1: Location of the Yangtze River Delta region

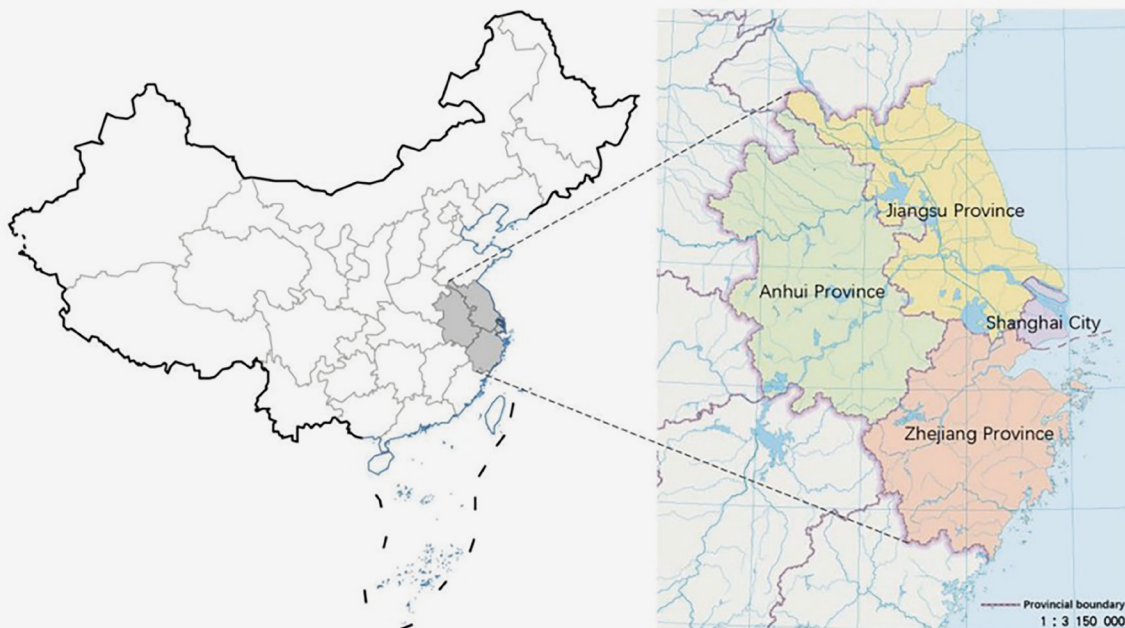

Source: Zheng et al., 2022<sup>2</sup>

<sup>1</sup> Similar to the devastating Texas cold wave in February 2021, the average temperature in the first 10 days of January 2021 in Shanghai reached 1.2°C, the lowest temperature recorded since 1987.

The Yangtze River Delta (YRD) region is a triangle-shaped metropolitan area located in the lower reaches of the Yangtze River in the eastern coastal area of China (see Exhibit 1, page 6). It covers a total area of 358,000 square kilometers, approximately the size of Germany, and encompasses Shanghai as well as the provinces of Jiangsu, Zhejiang, and Anhui. A snapshot summarizing the basic information of the YRD region is presented in Exhibit 2. As one of the most densely populated and economically advanced city clusters, with climate characteristics typical of southern China, the YRD region has the greatest potential to explore the zero-carbon heating pathway and become a role model for other regions in southern China.

**The poor winter indoor environment due to the lack of sufficient heating facilities in the YRD region requires urgent improvements to home heating systems.** Although the outdoor temperature in winter is not as low as that in the north (see Exhibit 3, page 8), the high air humidity makes people feel significantly colder in winter.<sup>ii</sup> However, most of the home heating devices currently used in the YRD region, primarily ductless mini-split system air conditioners (mini-splits) and small electric resistance heaters, are insufficient to create a comfortable indoor thermal environment.

In addition, 10%–30% of the residents in the region do not use any heating equipment.<sup>3</sup> As a result, the winter indoor environment in the YRD region is poor, with an average indoor temperature in the coldest month in winter falling below 15°C. For comparison, nearly 90% of households in similar climate areas in developed countries have winter indoor temperatures exceeding 20°C.<sup>4</sup>

## Exhibit 2: A snapshot of the YRD region

**Population:** 218 million (2020)

**Area:** 358,000 km<sup>2</sup>

**GDP:** US\$3,670 billion (2020)

**Climate:**

- o Humid subtropical climate according to the Köppen climate classification
- o Extreme hot and humid summer, cold winter
- o High air humidity throughout the year

**Residential building types:** Most residents in the YRD region live in high-rise apartments.

**Home heating systems:**

- o Distributed home heating systems (devices or systems installed in the apartment by the homeowner or real estate developer) are the norm in the YRD region. (District heating is the main heating approach in northern China.)
- o More than 60% of residents use mini-splits (with heating function) for space heating in winter, and small electric resistance heaters are also widely used; 10%–30% of the residents still have no heat in winter.<sup>5</sup>

ii High air humidity in cold weather increases the conduction of heat from the body and weakens the insulating qualities of clothing.

### Exhibit 3: Average hourly temperature in Shanghai

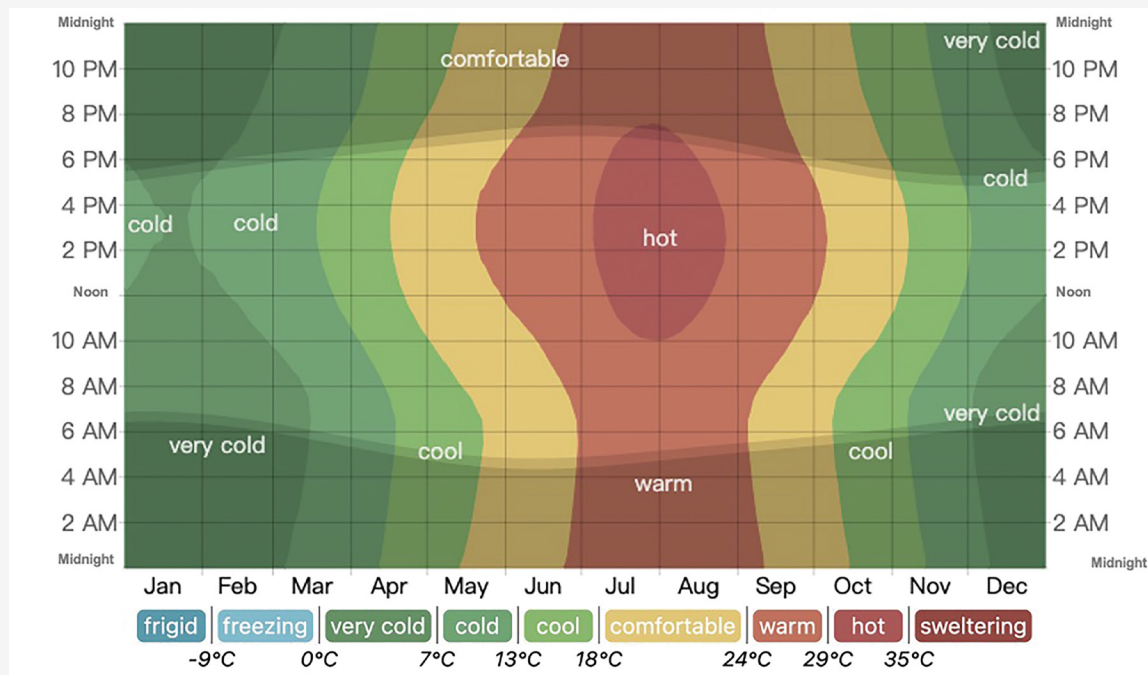

Source: WeatherSpark.com

**The advanced economic development in the YRD region lays the foundation for upgrading home heating systems.** The YRD region is the largest economic center of China, contributing more than 24% of the national GDP. In 2021, the per capita disposable income reached US\$7,350 per year (49,000 RMB per year), 1.5 times the national average. Residents of the YRD region are able and willing to pay for better home heating systems. With more than 200 million residents, the YRD region is home to 15% of China’s population and is one of the most densely populated areas in the world. The huge demand for better space heating there may also help the rapid development of the home heating manufacturing industry.

**The development of zero-carbon home heating is critical for the zero-carbon transition in the YRD region.** As China’s economic center and one of the global manufacturing centers, the region features high consumption and a high share of fossil energy, the majority of which is imported from other regions in China. The final energy consumption in the YRD region accounts for 17% of the national total, and the share of fossil energy is 89.4% of the total energy consumption. The rapid development of home heating in the YRD region will inevitably lead to the accelerated growth of energy demand. To achieve the regional zero-carbon transition, it is critical to develop the zero-carbon heating in the YRD region.

In short, the YRD region combines rising incomes, a lack of heating facilities, and the strong desire for better home heating systems. It is of vital importance for the YRD region to develop a zero-carbon home heating pathway, which would not only contribute to the regional zero-carbon energy transition, but also set a good example for other southern China provinces and global regions with similar climate features.

# Challenges of Home Heating in the Yangtze River Delta Region

## Development Trends in Home Heating

It is evident that home heating in the YRD region is growing rapidly, driven by multiple factors such as frequent extreme weather, increasing demand for better indoor environments, and population influx. Heating facilities are becoming standard in all new buildings, and residents of existing buildings are increasingly purchasing new heating equipment. Individual home heating devices instead of district heating systems will continue to be the dominant approach in the YRD region.<sup>iii</sup> The development trends of home heating in the YRD region are illustrated in Exhibit 4.

**Exhibit 4: Development trends in home heating in the YRD region (2020–2060)**

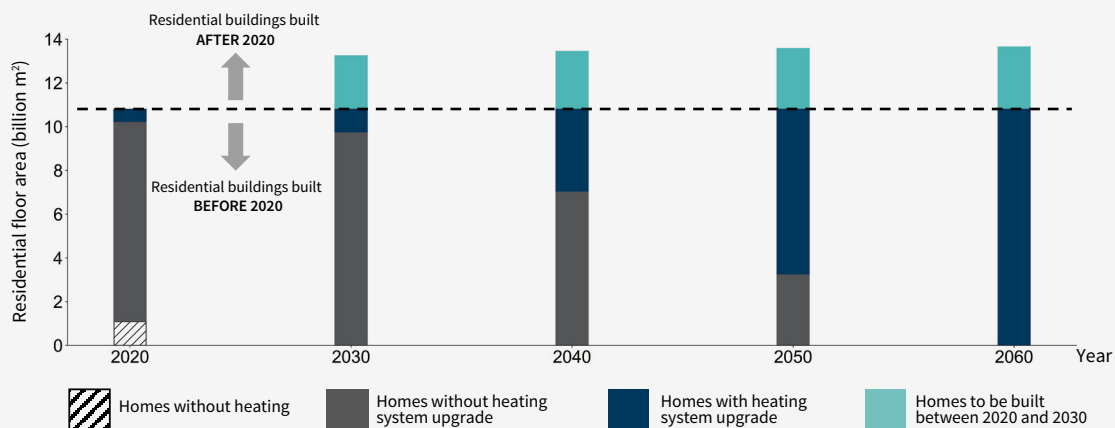

Source: RMI analysis

In the short term (2020–2030), the residential building floor area in the YRD region is expected to increase by 2.5 billion m<sup>2</sup>, 20% of the current residential floor area. More than 20 million residents, currently without home heating systems, will be equipped with new heating facilities. By 2030, there will be an increase of more than 500 million gigajoules of heating demand in the YRD region, equivalent to 40% of 2020's total heating demand.<sup>iv</sup> Home heating devices for the new buildings and the existing homes currently without heating contribute most to the growth.

In the long term (2030–2060), as new building construction peaks and retrofits of existing buildings are accelerated, upgrades of heating devices in existing residential buildings will create major momentum for heating device purchases. According to RMI's forecast, about 10 billion m<sup>2</sup> of residential floor area is expected to be improved by upgrading home heating facilities.

<sup>iii</sup> Multiple studies have shown that central heating is neither cost-effective nor energy-efficient for large-scale development in southern China due to the high investment required for infrastructure construction and the strong dependence on fossil energy.

<sup>iv</sup> Heating demand refers to the amount of heat required to maintain a comfortable indoor thermal environment in winter.

## **Challenge 1: Fossil fuel heating appliances are prevalent product in the YRD market**

According to RMI research, heating facilities have become standard in newly built residential buildings in the YRD region. Gas boilers are prevalent, used by about 80% of these newly built residential buildings. In existing residential buildings, an increasing number of residents are upgrading their home heating using gas boilers. The extensive use of gas equipment will bring challenges to the stability of the energy supply and the provincial climate goals in the YRD region.

According to RMI's analysis, the total annual residential gas consumption in the YRD region could reach 26 billion m<sup>3</sup> by 2030, about 2.5 times the total consumption in 2020, if new heating demand in the region is met entirely by gas-fired equipment. China has limited domestic gas production and consequently relies on imports. Demand for gas is also increasing owing to the implementation of "coal switch" policies in rural northern areas<sup>v</sup>. The large-scale use of gas heating in the YRD region will thus exacerbate the tight domestic gas supply. In addition, the surge of gas consumption in winter may pose major challenges to the extension of gas infrastructure in the YRD region.

Furthermore, the increasing application of gas equipment will lead to more direct CO<sub>2</sub> emissions in the building sector. If the current trend of gas domination in YRD's home heating continues, the emissions of residential buildings will increase, resulting in 56 million tons of direct CO<sub>2</sub> emissions from buildings caused by residential gas use by 2030. In the long run, from a 2060 perspective, if the building envelope remains at the current efficiency level, CO<sub>2</sub> emissions caused by home heating by gas equipment will dramatically increase to 120 million tons. If the building envelope is renovated, it could significantly reduce the building heating demand, leading to 45 million tons of CO<sub>2</sub> emissions by 2060 with the gas equipment applied. As a result, buildings remain as a huge barrier to the achievement of the regional climate goal.

## **Challenge 2: Heating facilities have a lock-in effect**

The lock-in effect of heating facilities means that the adoption of a certain type of heating facilities (such as gas boilers, heat pumps, or district heating systems) will lead to continuing use of such equipment for a long period. The effect has two dimensions:

### **The lock-in of energy consumption and carbon emissions within the service life of the heating device:**

The service life of a heating device is typically 10 years. Once a heating device is adopted, the energy use and CO<sub>2</sub> emissions will essentially be fixed for a decade. The CO<sub>2</sub> emissions of electric heating devices may decrease with the decarbonization of the power grid, but gas boilers will cause high carbon emissions during their whole service life.

**The lock-in of the heating pathway** means that the large-scale adoption of a type of heating facility will lead to path dependency owing to increased product awareness, corresponding policy support, and infrastructure development. Path dependency will also increase the cost of switching to another heating path. For example, the large-scale adoption of gas boilers will lead to the expansion of gas infrastructure and services, reduction in gas boiler costs, more supporting policies, and higher product awareness. These things in turn will allow gas boilers to dominate the heating market for decades, exacerbating the negative impact on the energy supply and the regional carbon neutrality goal.

To sum up, under the current trend of rapidly growing home heating demand in the YRD region, the extensive application of gas boilers and its lock-in effect will bring challenges to the local energy supply and the regional climate goal. Because the development of home heating is still at the early stage in the YRD region, developing and promoting energy-saving and low-carbon heating devices will be key to addressing this challenge.

<sup>v</sup> "Coal switch" is a central government-led policy aiming to decrease coal consumption and improve air quality by promoting equipment fueled by natural gas and electricity to replace small-scale coal-fired boilers and household coal-based heating and cooking systems, which are commonly used in rural areas in northern China.

# Comparative Analysis of Distributed Home Heating Systems in the YRD Region

Ideally, a home heating system should be able to provide a safe and healthful indoor environment while reducing greenhouse gas emissions and costs. However, because of the lack of unified evaluation methods such as energy efficiency labels, it is extremely difficult for consumers (including homeowners and real estate companies) and relevant policymakers to choose the most appropriate home heating system from the diverse products on the market. Having a set of unified criteria is critical for the comparison and evaluation of the major distributed home heating systems in the YRD region. In this section, we introduce the most typical home heating systems with their typical application scenarios in the YRD region, followed by a thorough comparison of the home heating systems from multiple dimensions.

## Major Distributed Home Heating Devices in the YRD Region

Distributed heating (also called decentralized heating) means that each household is equipped with one or more heating devices. As mentioned above, distributed heating currently is, and will continue to be, the most common means of heating in the YRD region. Distributed heating comes in various forms, including heat pump hydronic floor heating (HPFH) systems, mini-splits, electric resistance heaters, electric floor heaters, and gas boilers. Among them, HPFH systems and mini-splits both belong in the heat pump category, whose working principle is fundamentally different from that of other heating devices.

### Heat pumps

A heat pump is a device that can heat a building (or part of a building) by transferring heat (thermal energy) from low-temperature objects to high-temperature objects. Different from traditional home heating systems, which convert other forms of energy into thermal energy, a heat pump produces heat primarily by transporting the existing thermal energy in the environment. Its working principle is shown in Exhibit 5 (page 12). A heat pump is characterized by the following key features:

- **Being able to absorb heat from a low-temperature heat source:** A low-temperature heat source is a necessary condition for the operation of a heat pump, which enables the function of transporting heat from the low-temperature side to the high-temperature side. The energy efficiency of a heat pump is affected by the temperature of the heat source. Air source heat pumps (ASHPs), which use the ambient air as the heat source, are the most common heat pump models; other types include ground source heat pumps (GSHPs) and water source heat pumps (WSHPs).
- **Requiring input energy as the drive energy:** Similar to water pumps that use electric energy to carry water from a low position to a high position, heat pumps need input energy (normally electricity) to transfer heat from the low-temperature side to the high-temperature side. Gas heat pumps can be driven by a gas engine, and absorption heat pumps require an external (high-grade) heat source as a driver.
- **Having high energy efficiency:** Although heat pumps are driven by electricity input, the heat produced by a heat pump (to the high-temperature side) comes mainly from the heat absorbed from the low-temperature side. Usually, 1 kWh of electricity input can produce 3 kWh or more of heat (i.e., the heat pump absorbs 2 kWh or more heat energy from the low-temperature heat source), making the heating by heat pumps highly efficient.

- **Being able to provide both heating and cooling:** The heat pump transfers heat from the low-temperature side to the high-temperature side, and the high-temperature side becomes warmer as the low-temperature side becomes cooler. Therefore, heat pumps can also be used for space cooling in summer.

Heat pumps are commonly used for space and water heating in buildings. Among the different types of heat pumps (ASHPs, GSHPs, WSHPs), ASHPs are the most widely used heat pumps due to their ease of installation. In this report, we focus on the ASHPs used in residential buildings. In the YRD region, HPFH systems and mini-splits are the two most common types of ASHP used in residential buildings.

### Exhibit 5: Simplified schematic diagram of the heat pump working principle

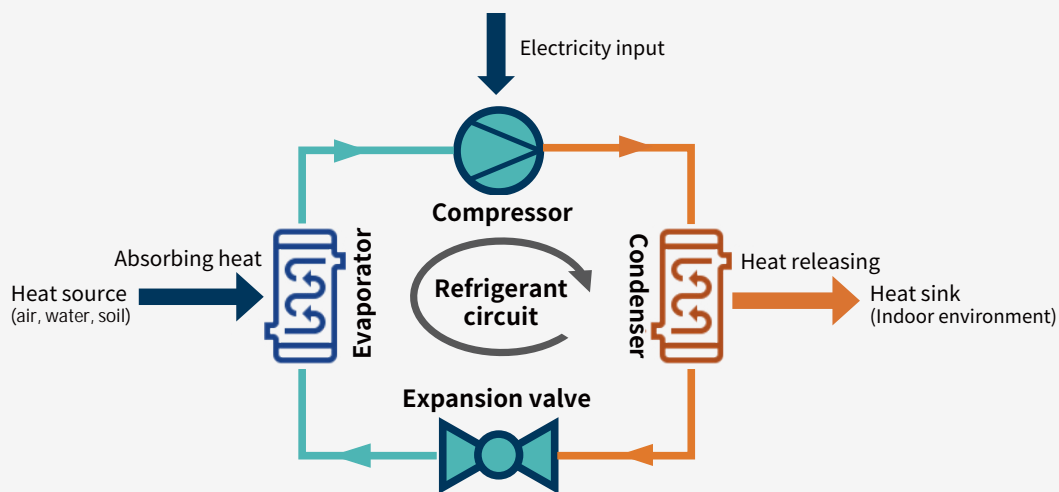

Source: RMI

### Heat pump hydronic floor heating system

Heat pump hydronic floor heating systems, or HPFH systems, are an emerging heating approach in the YRD region. HPFH systems are a type of air-to-water heat pump. Exhibit 6 (page 13) presents a simplified diagram of this kind of heating system. In summer, when the system is in the cooling mode, cold water (or the refrigerant) produced by the heat pump is sent to the indoor fan coil units to cool the indoor air. In winter, in the heating mode, the hot water produced by the heat pump is sent to the floor heating system. There is another form of air-to-water heat pump in which the heat pump sends the hot water to the radiators installed in each heated room. In the YRD region, floor heating is more popular than other forms that can be coupled with heat pump units because of the HPFH systems' ability to provide greater indoor comfort. In addition, the heating hot water supply temperature of floor heating is typically 35°C–40°C, lower than that of radiators (typically 50°C). The lower supply water temperature will further enhance the energy efficiency of heat pump systems.

## Exhibit 6: Simplified system diagram of HPFH system

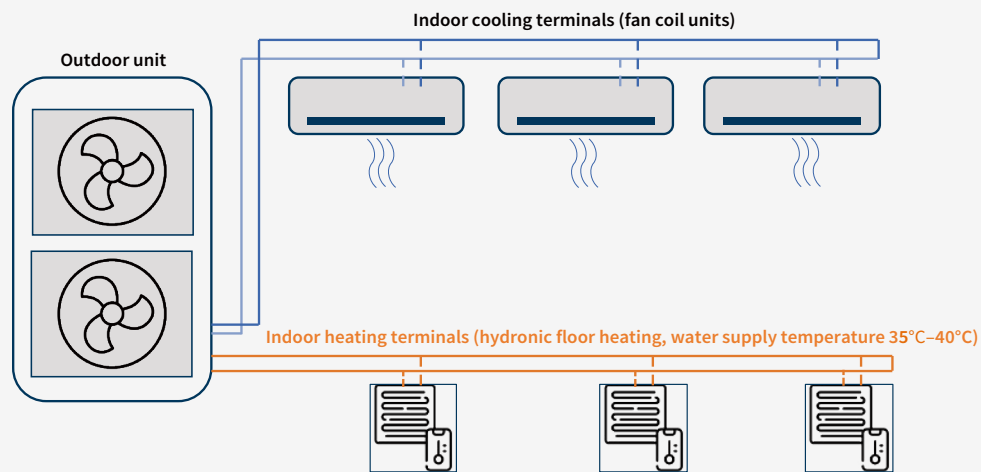

Source: RMI

### Mini-split

Mini-split refers to air conditioning equipment with both cooling and heating functions. It has two main components, an outdoor unit and an indoor air-handling unit. As a type of air-to-air heat pump, a mini-split unit directly heats the air and sends it into the room. In the YRD region, mini-splits are designed primarily for the cooling mode in summer; hence, they are normally not suitable for heating use under extreme cold weather conditions (In fact, there are emerging mini-split products that are specifically designed for the extreme cold region, but they are not the focus of this study). Mini-splits are also normally equipped with a supplementary electric resistance heating element to be able to provide sufficient heat, so their energy efficiency is lower than that of HPFH systems. There are also other types of air-to-air heat pumps, for example, ducted heat pumps; however, these types are rarely seen in residential buildings in the YRD region. Our study is therefore focused on the mini-split unit, which typically meets the heating demand of only a single room.

### Other common distributed heating devices

#### Gas boiler

Gas boilers burn natural gas to heat water that's used for central heating or hot water. Gas boilers are most commonly connected with floor heating systems (in new buildings) and radiators (in retrofits of existing buildings). For the sake of better comparability with HPFH systems, gas boilers with floor heating systems are the focus of this study. Gas boilers burn fossil fuels to produce heat, resulting in more direct carbon emissions in buildings than would be produced by electric heating devices. In addition, gas boilers can provide only heating; additional devices are needed for cooling.

#### Electric floor heating system

The electric floor heating (EFH) system is a new type of floor heating. Unlike the abovementioned floor heating system that uses hot water as the heat medium, an EFH system uses heating cables laid below the floor to heat the room. Compared with water-based floor heating systems, an EFH system is fast-response (that is, it is able to heat the space quickly) and easier to maintain. However, EFH systems are often more expensive and more energy-intensive than heat pump systems. For YRD residential buildings, EFH system use around three times more electricity than heat pumps.

### Portable electric resistance heater

The term portable electric resistance heater (PERH) generally refers to small heating devices that convert electricity directly into thermal energy. Compared with other heating systems, PERHs are much cheaper and easier to use. However, they are normally unable to provide sufficient heat to the entire room. Therefore, a PERH usually serves as a supporting heating device, heating just part of the space where people stay. In the YRD region, it's very common for people to combine mini-splits and PERHs in their home.

## Multidimensional Comparison

To evaluate and compare the abovementioned five typical home heating systems in the YRD region, we first defined 54 home heating scenarios typical in the region, and then modeled 1 year of energy use for space heating to determine the carbon emissions and the 10-year net present cost of each scenario.

The variables making up the 54 scenarios are shown in Exhibit 7. Given that the heating demand of residential buildings is determined primarily by geographic location, building envelope, floor level, and apartment size, we selected parameters related to these variables to define the most typical scenarios of home heating in the YRD region. For geographic location, we selected three cities — Xuzhou in Jiangsu Province, Shanghai, and Wenzhou in Zhejiang Province — to represent cold, mild, and warm winter climate types in the YRD region, respectively.

Typical building envelope, energy code-compliant building envelope, and enhanced envelope were selected to represent poor, normal, and excellent building thermal insulation conditions, respectively (the parameters of each envelope structure are listed in Appendix A). In addition, floor and apartment size have an impact on the heating demand of buildings. In this study, bottom floor, middle floor, and top floor were selected as variables, and the two most common apartment sizes in the YRD region were considered as well (see Appendix A).

In addition to carbon emissions and economics, we considered other factors closely related to the user experience, such as the ability to provide indoor thermal comfort and the complexity of installation and maintenance, enabling a more comprehensive analysis of the advantages and disadvantages of the five heating system types.

### Exhibit 7: Home heating scenario characteristics in the YRD region

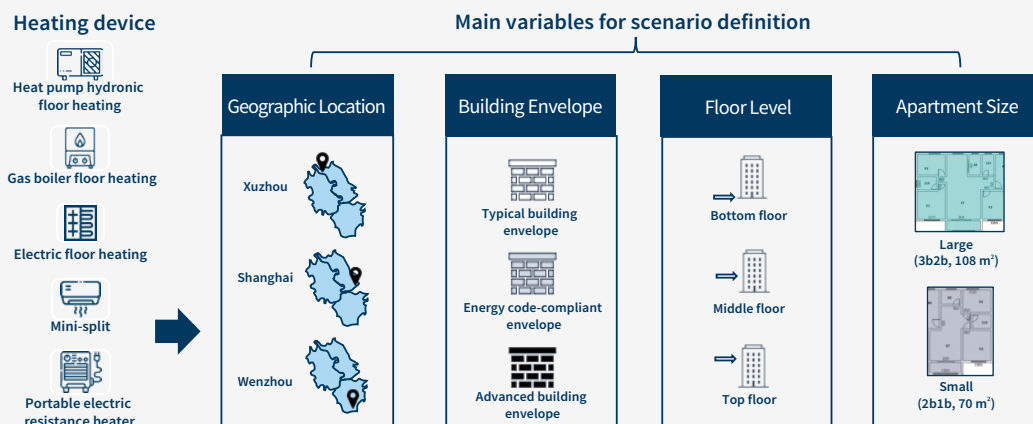

Source: RMI

## CO<sub>2</sub> emissions comparison

The carbon emissions of heat pumps for home heating are the lowest in all the 54 scenarios defined; the cumulative CO<sub>2</sub> emissions are 30%–70% less than emissions produced by the competitors within the 10-year life span. Furthermore, compared with gas boilers, heat pumps could further lower the CO<sub>2</sub> emissions of home heating as the electric grid becomes greener. The cumulative emissions of heat pumps for home heating during 2020–2060 are 50% less than that of gas boilers.

Home heating contributes to CO<sub>2</sub> emissions directly and indirectly.<sup>vii</sup> Gas boilers burn natural gas to generate heat, resulting in direct CO<sub>2</sub> emissions. Indirect CO<sub>2</sub> emissions come from power plants that burn fossil fuel to generate electricity to power the electric heating devices. The indirect CO<sub>2</sub> emissions of home heating systems are calculated by multiplying the amount of electricity used for home heating by the carbon intensity of the regional grid.<sup>viii</sup>

Exhibit 8 shows the 10-year cumulative CO<sub>2</sub> emissions comparison of the five typical home heating systems in different cities and sizes of apartment. The impact of envelope structure and floor is presented by the error bars (vertical line on the bars) in the exhibit. The CO<sub>2</sub> emissions of home heating are strongly affected by the location and the apartment size: larger apartment size and colder climate lead to significant increase in CO<sub>2</sub> emissions caused by home heating. However, in all the scenarios modeled, the CO<sub>2</sub> emissions caused by heat pumps, including mini-splits and HPFH systems, were lower than those caused by other home heating systems.

The CO<sub>2</sub> emissions of HPFH systems are the lowest among the five typical heating systems thanks to the high energy efficiency of those systems. Taking a large apartment in Xuzhou as an example, home heating using the HPFH system created just 70% of the CO<sub>2</sub> emissions of a gas boiler floor heating system, and about 30% of the emissions of an electric floor heating system, which has the highest CO<sub>2</sub> emissions due to that system's low efficiency.

**Exhibit 8: 10-year cumulative CO<sub>2</sub> emissions of various home heating systems by apartment size and city**

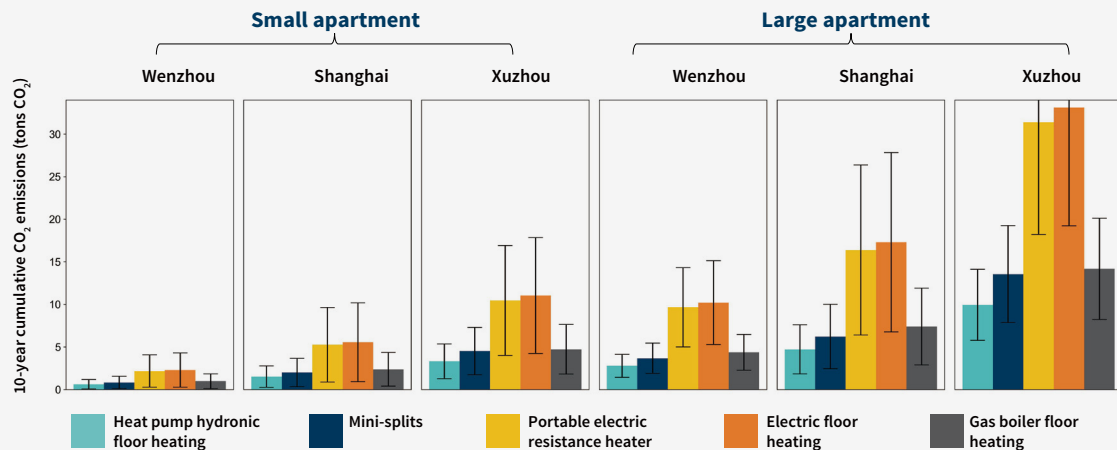

Source: RMI analysis

vii The CO<sub>2</sub> emissions of the home heating systems in this study are calculated under the assumption that the indoor temperature of the entire home is maintained at 18°C in winter.

viii CO<sub>2</sub> emissions per kWh of electricity generated (kg CO<sub>2</sub>/kWh). The regional average carbon intensity is used in this study.

Exhibit 9 shows the annual CO<sub>2</sub> emissions of various home heating systems taking into account the decarbonization of the power grid from 2020 to 2060. In 2020, even with the current grid carbon intensity in the YRD region, the CO<sub>2</sub> emissions of HPFH systems were lower than those of gas boilers. With the rapid decarbonization of the power grid, HPFH systems' advantage in emissions reduction will become more prominent; they will achieve net zero by 2060 once zero-carbon electricity is used by buildings.<sup>ix</sup> On average, HPFH systems could reduce CO<sub>2</sub> emissions by more than 50% compared with gas boiler heating. The savings would be even higher when compared with electric floor heating and electric resistance heaters.

### Exhibit 9: Annual CO<sub>2</sub> emissions of home heating using various home heating systems considering the decarbonization of the power grid from 2020 to 2060

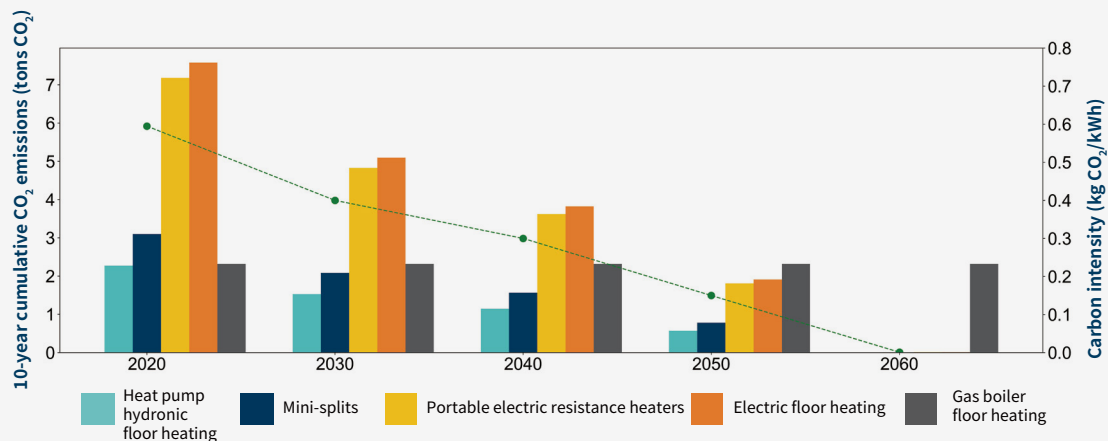

Source: RMI analysis

---●--- Carbon intensity of the electricity consumed in buildings

### Economic analysis

Heat pumps have the advantage of low operating costs. However, the overall cost-effectiveness of heat pumps depends mainly on the up-front costs. As a type of heat pump, mini-splits have the best cost-effectiveness among the five home heating systems in the YRD region thanks to the low equipment costs. High up-front costs make HPFH systems less cost competitive in the YRD region.

To evaluate the cost-effectiveness of the various home heating systems, we calculated and compared the life-cycle cost of the five different home heating systems in the predefined 54 home heating scenarios. The life-cycle cost includes capital cost, operating cost (energy bills for home heating in winter), maintenance cost, and salvage value of the devices.

The definition of each cost and the assumptions used in this study appear in Appendix B. For the sake of comparison, the life-cycle cost is presented as the 10-year net present value and the equivalent annual cost in this study.<sup>x</sup> This corresponds to the annual expenditure on home heating.

ix Given the rapid deployment of distributed solar photovoltaic panels (PVs), such as rooftop PVs, in the building sector, we predict that electricity used in buildings will become zero carbon by 2060.

x Present value is the value of future cash flows converted to the present. The total present value of all cash flows over the life cycle is the net present value. The equivalent annual cost is the annual value of the net present value during the life cycle.

## Exhibit 10: Equivalent annual costs of various home heating scenarios

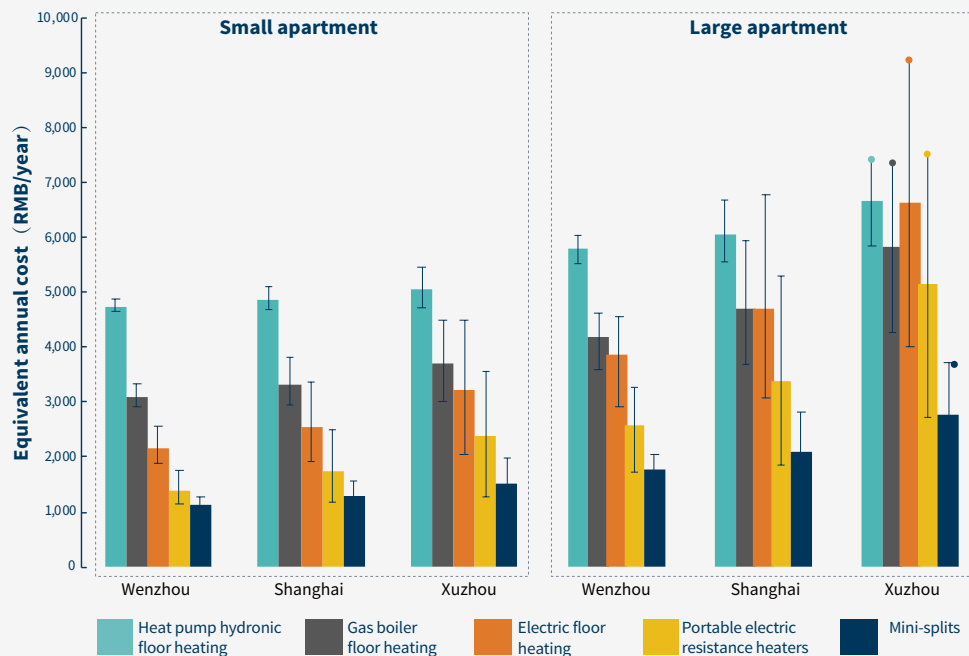

Source: RMI

Exhibit 10 shows the equivalent annual costs of various home heating scenarios. (The error bars in the exhibit represent the variances created by the envelope structure and floor.) In most analyzed scenarios, HPFH systems cost more than the other home heating systems, whereas mini-splits have the best cost-effectiveness. In small apartments, the equivalent annual cost ranges from 4,670 to 5,450 RMB (US\$689 to US\$804) for HPFH systems and 1,040 to 1,970 RMB (US\$153 to US\$290) for mini-splits. In larger apartments, the annual cost rises to 5,520 to 7,430 RMB (US\$814 to US\$1096) and 1,440 to 3,710 RMB (US\$212 to US\$547), respectively.

The average equivalent annual cost of gas boiler floor heating and electric floor heating is also lower but fluctuates more than that of HPFH systems (see error bars in Exhibit 10). In some scenarios, the life-cycle cost of gas boiler floor heating and electric floor heating meets or exceeds that of HPFH systems.

The cost-effectiveness of heat pumps improves with increased heating demand. As mini-splits have already shown the best economics among all the compared systems, we compared the three floor heating systems (HPFH, gas boiler floor heating, and EFH) to showcase how the heating demand affects the economics of the floor heating systems with different heat sources. In the modeled scenario with the largest heating demand, the equivalent annual cost of a HPFH system is about 7,432 RMB (US\$1,101), much lower than the 9,214 RMB (US\$1,365) of an electric floor heating system, and close to the 7,366 RMB (US\$1,091) of a gas boiler floor heating system (see Exhibit 11, page 18). Multiple factors contribute to the increase in heating demand, including lower winter temperatures, less insulated envelope, larger apartment sizes, and floor level. Our analysis shows that the life-cycle cost of HPFH systems will become lower than that of gas boiler floor heating systems when annual heating demand exceeds 11,500 kWh, equivalent to an annual gas consumption of 1,500 m<sup>3</sup> for heating use.

## Exhibit 11: Comparison of equivalent annual costs in lowest- and highest-heating-demand scenarios

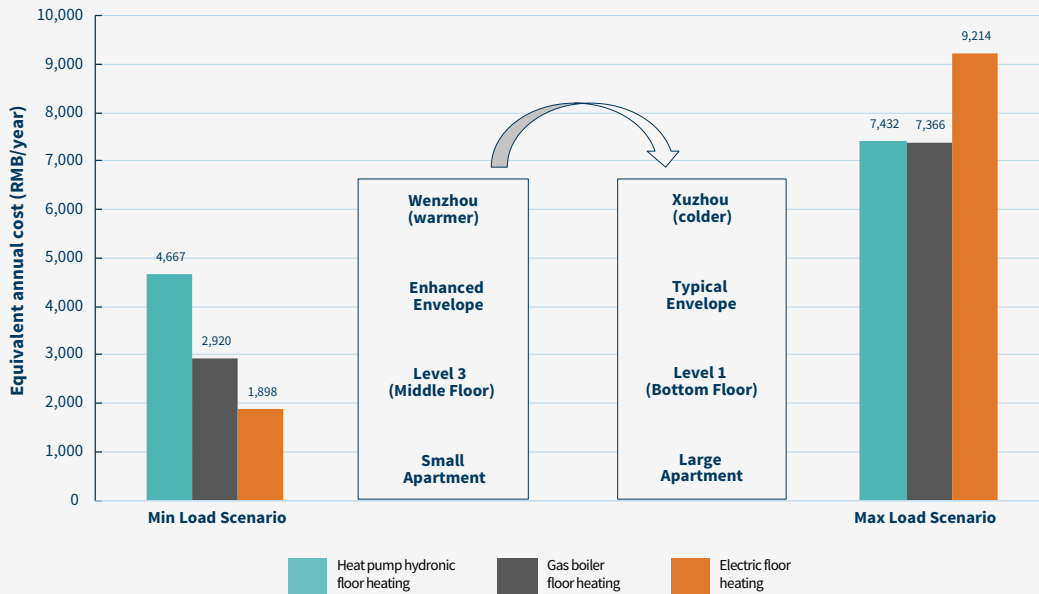

Source: RMI analysis

Heat pumps have considerably lower operating costs; however, the overall cost-effectiveness is determined primarily by their up-front costs. Among all analyzed home heating systems, HPFH systems have the lowest operating cost. However, the operating cost savings are unable to offset the huge up-front cost difference, resulting in an overall higher life-cycle cost for a HPFH system compared with its competitors (see Exhibit 12). Mini-splits enjoy both low operating costs and low up-front costs, making them the most cost-effective home heating system in the YRD region.

## Exhibit 12: Breakdown of the life-cycle costs of the five home heating systems

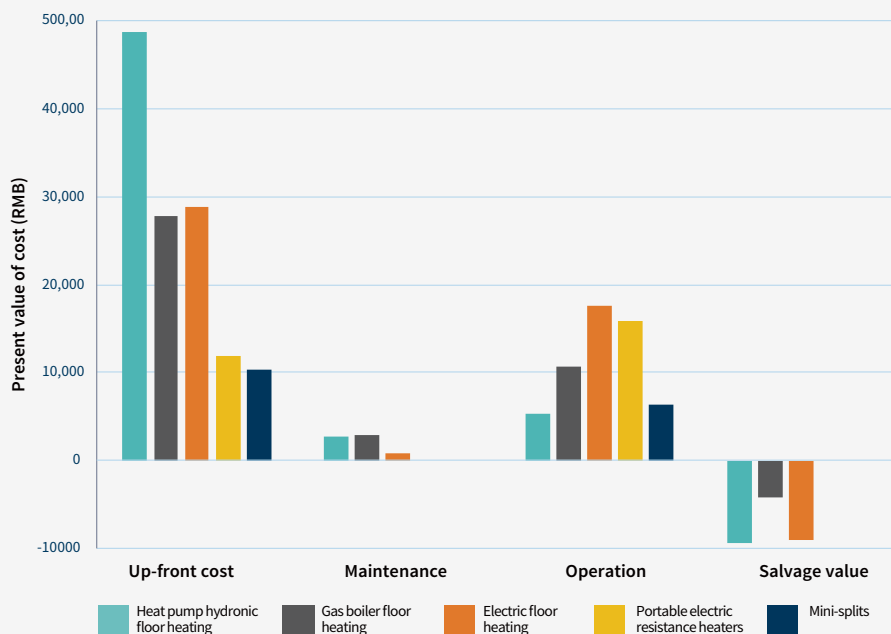

Source: RMI analysis

To further clarify why the HPFH system costs more than its competitors and how to improve its cost-effectiveness, we conducted a sensitivity analysis (see Exhibit 13). It considered the potential impact of factors such as up-front cost, electricity rates, discount rates, and the efficiency of heat pumps on the life-cycle costs of HPFH systems. Key findings are as follows:

- The up-front cost of the HPFH (including outdoor units and indoor systems) has the most significant impact on the life-cycle cost-effectiveness. The impact of the outdoor unit price exceeds that of the indoor system.
- An increased discount rate significantly reduces the cost competitiveness of HPFH systems.<sup>xi</sup>
- Electricity rates have a limited impact on the economy of HPFH systems. The power price mainly affects the operating cost of the HPFH system. However, the operating cost accounts for a much smaller share of the life-cycle cost of the HPFH system than does the up-front cost.
- Increasing the COP has a limited impact on improving the cost-effectiveness of HPFH systems.

**Exhibit 13: Change in equivalent annual cost when selected variables increase (in the scenario of a large apartment with typical building envelope in Shanghai)**

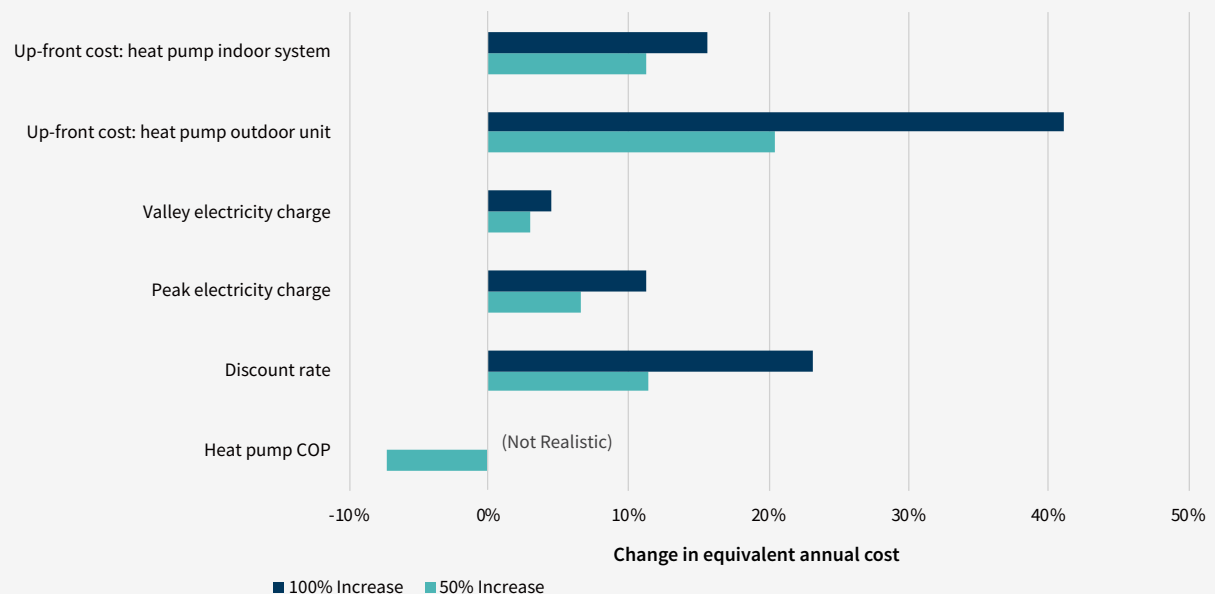

Source: RMI analysis

xi The discount rate expresses the time value of money in discounted cash flow.

## Comfort and health

HPFH systems are the healthiest and most comfortable heating choice considering temperature, humidity, noise, and air quality. HPFH systems, gas boiler floor heating, and EFH can provide more uniform temperature distribution, a better humidity level, and better heating comfort. HPFH systems can also provide better indoor air quality than gas boiler floor heaters.

Temperature, humidity, and noise are the most critical factors affecting indoor comfort. We considered these three factors in evaluating the performance of home heating systems in terms of indoor comfort in winter. Indoor air quality (including elements such as allergens, dust, and CO<sub>2</sub> concentration) also needs to be taken into consideration, as it affects not only indoor comfort but also occupants' health.

The heat transfer methods of heating systems have important impacts on the above factors. Among the five common distributed home heating systems, HPFH systems, gas boiler floor heaters, and EFH systems heat the space with floor heating, whereas mini-splits use a forced air system. The following sections will compare and evaluate the impact of different home heating systems on comfort and health.

Temperature distribution is very important in indoor comfort. Exhibit 14 compares the impact of forced air systems (applied by mini-splits) and floor heating (normally applied by HPFH systems, gas boiler, and EFH systems) on temperature distribution. With floor heating, the human body can reach the ideal temperature for optimal thermal comfort. This is determined by the different heating approaches of the two systems: floor heating can form a comfortable indoor temperature distribution through radiative heat dissipation, warming residents' feet first; mini-splits, which heat the room by blowing hot air into it, could cause the uncomfortable feeling of "warm head and cool feet" because the air outlet is typically located near the ceiling and warmer air also flows upward.<sup>xii</sup>

### Exhibit 14: Comparison of comfort levels of mini-splits and floor heating

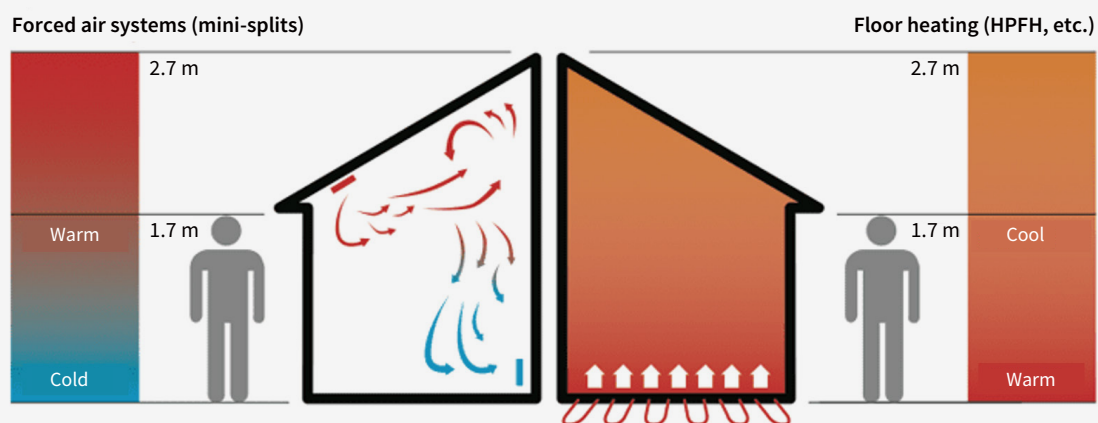

Source: Stephanie Cernivec, 2018<sup>6</sup>

xii Many of the mini-splits manufacturers have been working on developing more advanced mini-split products that are able to provide higher indoor comfort (e.g., by adjusting the airflow pattern). However, the most typical mini-splits on the YRD market currently are still confronting the problem of indoor discomfort.

In terms of humidity, typical existing home heating systems cannot adjust indoor humidity in heating mode. Furthermore, mini-splits often cause a drier feeling indoors since they use forced top-down air distribution. This supplies strong air flow toward the occupant’s head and accelerates evaporation of the moisture in the air and from the skin. In contrast, hydronic floor heating and radiators heat the room through radiation, which greatly reduces the dry feeling.

Noise is another important consideration. Hydronic floor heating and electric resistance heaters operate quietly, avoiding the noise created by mini-splits’ air supply. Similarly, EFH systems are very quiet. In comparison, the outdoor units of HPFH systems and gas boilers both produce a certain amount of noise, but the impact is limited since these devices are typically installed far away from the bedrooms and living rooms (the unit of heat pumps that produces noise is installed outdoors; the gas boiler is typically installed in the kitchen).

Introducing fresh air is an important measure in improving indoor air quality. At present, most zone-level home heating systems do not have fresh air systems. Fresh air comes in through infiltration and open windows, which not only is insufficient but also introduces outdoor pollutants. Some of the more advanced HPFH systems can be equipped with a mechanical ventilation module that may help improve indoor air quality. Mechanical ventilation systems equipped with filter (HEPA/MERV) devices can effectively filter outdoor air pollutants. More accurate mechanical control could ensure sufficient fresh air. More advanced mini-splits on the market today also can provide fresh air ventilation but the fresh air intake is usually small, leading to limited improvement of indoor air quality.

The advantages and disadvantages of various distributed home heating systems in terms of comfort and health are shown in Exhibit 15.

**Exhibit 15: Comparison of comfort and health levels of different heating options**

Comparison dimensions	Mini-Split	HPFH system	Gas boiler	EFH	PERH
<b>Temperature</b>	Could lead to unevenly distributed temperature; feeling of blowing air could lead to poor comfort level as well	Ideal temperature distribution and high comfort level, but the heating process is relatively slow			Unevenly distributed temperature leads to poor comfort level
<b>Humidity</b>	Air system may lead to feeling of dryness	Doesn't include air system so there's no feeling of blowing air and less feeling of dryness			
<b>Noise</b>	Air system may generate noise	Low noise	Low noise	Minimal noise	Minimal noise
<b>Air Quality</b>	Some models may provide fresh air, which improves indoor air quality	Optional fresh air ventilation and dehumidification module could improve indoor air quality; dehumidification module could improve indoor air quality	Normally doesn't have fresh air ventilation		

Source: RMI

## Other dimensions

Ease of installation and compatibility with future energy systems are also important factors in the choice of home heating systems. These dimensions affect energy consumption and carbon emissions in addition to the above-discussed three major comparison dimensions (CO<sub>2</sub> emissions, economics, and comfort). This section will consider the dimensions of ease of installation and power system compatibility.

### Ease of installation

Hydronic floor heating is hard to install. Installation of gas boiler floor heaters, HPFH systems, and EFH systems includes laying pipelines or heating cables and supporting facilities under the floor, greatly increasing the complexity of construction, which will affect users' choices to a certain extent. Smaller appliances such as mini-splits and electric resistance heaters are significantly easier to install, especially in existing buildings, where users are likely to choose "plug and play" types of heating systems without retrofitting their homes. Moreover, HPFH systems usually require large volumes of outdoor units, making them impossible to install in old residential buildings in the YRD region due to spatial and structural constraints.

### Compatibility with the power system

On the path to a future zero-carbon energy system, electrification has been considered as one of the most viable and efficient approaches. Compared to the industry and transportation sectors, the buildings sector could be considered easier to electrify, as electrified equipment is already available in the market as an alternative to gas boilers/stoves. Due to its high energy efficiency and heat storage capacity, the HPFH system is most compatible with the power system compared with other common home heating options in the YRD region.

Electrifying all heating systems in the YRD region would lead to a substantial increase in regional power consumption and peak power load, resulting in an increase in indirect carbon emissions and a challenge to the stable operation of the power grid. To deal with this problem, using highly efficient heat pumps would lead to lower electricity demand and provide the same amount of heat, resulting in less impact on the power system compared with less efficient electric resistance heaters and EFH systems.

In addition, improving the flexibility of the power system is becoming critical given the increasing share of renewable energy generation such as solar PV and wind in the power system. Demand response is often a more economical approach to providing flexibility than deploying more energy storage facilities on the supply side (such as battery storage). In the HPFH system, the floor can also serve as heat storage and reduce the electricity peak of the grid. This can be accomplished by running the hydronic system in advance of the peak period of power demand or when renewable generation is abundant, then releasing the stored heat energy when needed. In this way, demand-side load management (load shifting) can be accomplished at a very low cost without sacrificing indoor comfort.

The shifting and adjustment of demand-side load using heat pumps has become one of the hot research topics in recent years. Studies showed that load shifting can be achieved for up to six hours by installing additional thermal buffering in heat pump systems.<sup>7</sup> The flexibility provided by retrofitting old building envelopes and the adoption of heat pump technology can greatly reduce the cost of installing required energy storage for the new power system.<sup>8</sup>

## Conclusions

We compared five commonly used home heating systems in the YRD region (see Exhibit 16) along multiple dimensions and found that heat pumps (including HPFH systems and mini-splits) were the better choice that is in line for the trend of upgrading home heating systems and pursuing the zero-carbon transition. Its carbon emissions are significantly lower than those of other systems. The HPFH systems are capable of providing demand response to ease the burden on future power systems. However, HPFH systems also face certain challenges, including being economically inefficient owing to their high up-front investment, having a complicated installation process, and offering low heating flexibility.

**Exhibit 16: Multidimensional comparison of five home heating systems**

		Heat pumps		Other systems		
		HPFH system	Mini-splits	PERH	EFH	Gas boiler
Comfort and health		★★★	★★☆	★☆☆	★★★	★★★
CO <sub>2</sub> emissions reduction		★★★	★★☆	★☆☆	★☆☆	★☆☆
Cost-effectiveness		★☆☆	★★★	★★★	★★☆	★★☆
Other dimensions	Ease of installation	★☆☆	★★☆	★★★	★☆☆	★☆☆
	Compatibility with the power system	★★★	★★☆	★☆☆	★☆☆	★☆☆

Note: More solid stars indicate more significant advantages over other choices in this comparison dimension.

Source: RMI

In practice, occupants' needs can often be divided into two categories:

**o Users who are relatively insensitive to indoor comfort:** Mini-splits and electric resistance heaters are two home heating systems used by users who are less sensitive to indoor comfort. Electric resistance heaters are relatively cheaper and more flexible; however, they are not suitable to be used as a major home heating system owing to their low energy efficiency.

**o Users who have higher requirements for indoor comfort:** Users with higher requirements for comfort are more inclined to choose radiant home heating systems (HPFH systems, gas boilers, and electric floor heaters), and HPFH systems are the best option. HPFH systems have significant advantage in energy saving and carbon emissions reduction, HPFH systems provide a better indoor thermal environment than the other two floor heating systems because they can provide both heating and cooling. HPFH can also bring in fresh air and control humidity. For homes with higher heating demand (larger indoor area, relatively colder climate, and closer to the top or bottom floor of the building), the cost-effectiveness of HPFH systems also improves significantly owing to the higher energy efficiency.

# Pursuing a Zero-Carbon Pathway by Scaling Heat Pumps in the Yangtze River Delta Region

Home heating in the YRD region is in the early stages of development and transition, and choosing energy-saving and low-carbon heat pump systems (rather than gas-fired systems) will be a key enabler for the zero-carbon transition of home heating in the region. Research by RMI shows that the adoption of heat pumps in the YRD region could save nearly 600 million tons of CO<sub>2</sub> cumulatively by 2060 compared with using gas-fired heating.

To analyze the total emissions reduction potential of heat pump heating in the YRD region, this study sets two scenarios for home heating: a reference scenario and a zero-carbon scenario. In the reference scenario, gas-fired systems will be widely used in new buildings, followed by rapid expansion, finally forming a home heating pattern dominated by gas in 2060. In the zero-carbon scenario, the promotion of heat pump systems in new buildings deters large-scale deployment of gas-fired systems, enabling heat pumps to gradually replace and finally phase out existing gas-fired systems. A comparison of heating choices in the two scenarios is shown in Exhibit 17.

**Exhibit 17: Adoption of equipment in reference scenario and zero-carbon scenario (2020–60)**

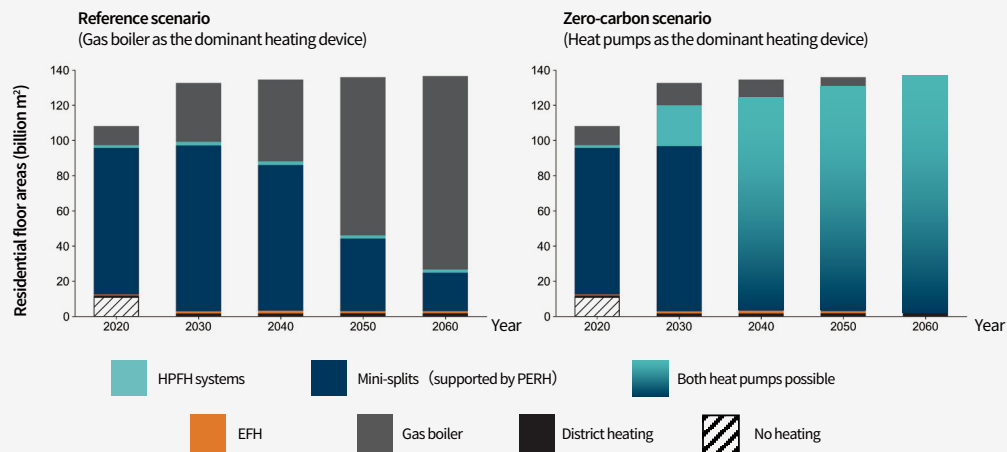

Source: RMI analysis

As shown in Exhibit 18 (page 25), under the reference scenario, the overall carbon emissions of home heating will rise at first, then decline and finally flatten. During 2020–30, the widespread adoption of gas-fired systems in new buildings will be the main reason for the increase of carbon emissions from home heating. During 2030–40, when gas-fired systems have not been widely promoted in existing buildings

and most still use mini-splits for heating,<sup>xiii</sup> the overall carbon emissions of home heating will decline with the retrofit of building envelopes and the reduction of the grid carbon intensity. During 2040–60, the share of gas-fired heating systems in existing buildings will gradually increase due to the scale effect, and the emissions reduction enabled by retrofits will gradually be offset by the emissions growth caused by the use of gas. By 2060, home heating in the YRD region will still create about 45 million tons per year of CO<sub>2</sub> emissions.

Under the zero-carbon scenario, the overall carbon emissions of home heating will be flat at first, followed by continual decline. During 2020–2030, as HPFH systems are adopted as the major heating systems in new buildings, the overall carbon emissions of home heating will be flat due to the offset of increasing heating demand and decreasing carbon intensity of the power grid. During 2030–2060, the carbon emissions of home heating will decrease thanks to the upgrade of building envelopes and the popularization of heat pumps. The large-scale adoption of heat pumps and the gradual decarbonization of the power system make zero-carbon home heating possible by 2060. Compared with the reference scenario, the zero-carbon scenario will cumulatively reduce CO<sub>2</sub> emissions by about 600 million tons from 2020 to 2060. Of that reduction, 200 million tons will be contributed by buildings built after 2020 and 400 million tons by buildings built before 2020.

### Exhibit 18: Overall carbon emissions of home heating in the YRD region under different scenarios

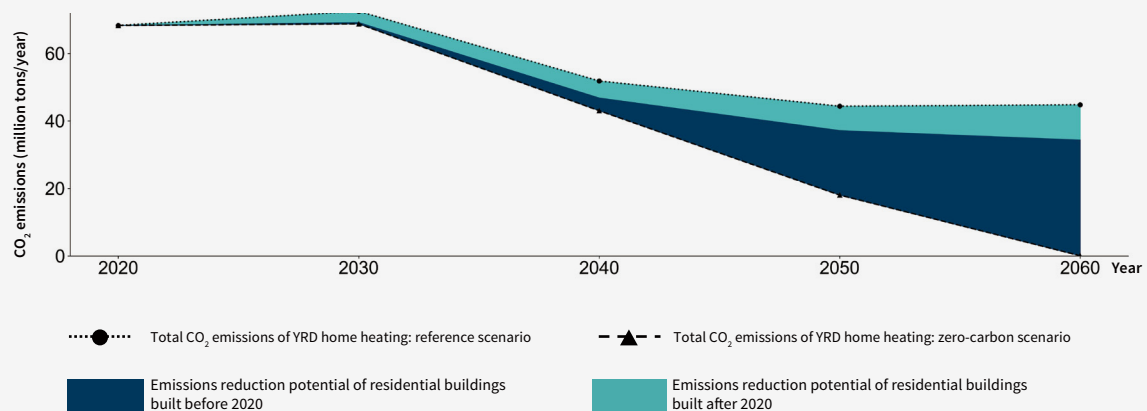

Source: RMI analysis

At present, the rapid development of gas-fired heating systems (especially in new buildings) is bringing great challenges to the zero-carbon transition of home heating in the YRD region. The key to solving this problem is to accelerate the promotion of heat pump systems for home heating as soon as possible, rolling them out in different types of buildings in stages. Based on the above scenario analysis, the promotion of heat pumps for home heating in the YRD region can be roughly divided into the following three stages:

xiii In the assumptions of home heating scenarios in the YRD region, mini-split refers to the heating mode that takes mini-split air conditioners as the main source of heating and electric resistance heaters as supplementary heating. Because electric resistance heaters are often used as supportive heating devices, they are not listed as a separate system in the analysis.

· **Stage I: The initial stage of the home heating system transition (2020–30). The heated residential floor area and heating market continues to grow, promoting the adoption of heat pumps for heating in new buildings.** In this stage, households in new buildings and existing buildings without heating are faced with the choice of new home heating systems. Preventing these users from choosing gas-fired systems is the primary task in this stage. Efforts should be made to vigorously promote the adoption of HPFH systems in new buildings and encourage households in existing buildings without heating to use mini-splits instead of gas boilers. By 2030, all residents in the YRD region will have access to heating, with about 20 million residents installing home heating systems from nothing. About 17% of residents in the region will adopt heat pumps for heating, 15% more than the 2020 level. The expansion of gas boilers will be curbed and maintained at the 2020 level of about 10%.

· **Stage II: The mid-stage of the home heating system transition (2030–45). Heat pumps will be widely promoted in existing buildings, reducing the share of gas-fired heating systems.** In this stage, replacement of existing systems becomes the driving force in the home heating system transition. Gas-fired systems will be gradually replaced by HPFH systems as they approach the end of their life span, and their share of the home heating sector will decline to less than 5% by 2045. Meanwhile, with more buildings being retrofitted and the increasing requirement for the indoor thermal comfort, HPFH systems will also replace some of the mini-splits in existing buildings and become a mainstream home heating system.

· **Stage III: The final stage of the home heating system transition (2045–60). Gas-fired heating systems will be completely phased out, and the goal of zero-carbon home heating will be achieved.** In this stage, gas-fired heating systems and less-efficient electric floor heaters will be completely replaced by heat pumps. Except for a small number of residential buildings with centralized heating, all home heating demand in the YRD region will be met by heat pumps.<sup>xiv</sup> With the decarbonization of electricity used by buildings, zero-carbon home heating will be achieved by 2060.

<sup>xiv</sup> Centralized heating includes district heating that uses urban heating networks and the heating approach that uses a unified heat source to provide heating to a community. Under the zero-carbon scenario, centralized heating should adopt zero-carbon heat sources such as central heat pumps, industrial waste heat, and biomass boilers to ensure the decarbonization of home heating.

# Major Challenges and Suggestions to Promote Heat Pumps in the YRD Region

In response to China's national climate pledge and rising demand for better indoor comfort in the YRD region, heat pumps are the best solution. However, the large-scale adoption of heat pumps still faces many challenges. Based on previous analysis, this section will summarize the challenges of promoting heat pumps for heating in the YRD region and then provide suggestions for multiple stakeholders.

## Major Challenges

**High purchase cost is the biggest barrier to the use of HPFH systems.** According to RMI's analysis, installation of heating systems in new residential buildings has become a mainstream practice in the YRD region, with real estate developers playing a decisive role in the choice of home heating systems. The purchase cost of a gas-fired floor heating system is about 15% lower than that of an HPFH system, which is the main reason gas systems are currently the preferred heating approach. If there is no preferential policy for heat pump promotion, developers tend to choose to install the cheaper system.

**Low public awareness of HPFH hinders the use of heat pumps.** Many users are not aware of heat pumps at all, because of the products' lower penetration rate compared with other home heating devices. Some users may have heard of heat pumps but are not fully aware of their advantages in terms of comfort, environmental benefits, and low operating costs. In addition, the lack of convenient online/offline purchasing channels constrains users' adoption of heat pumps.

**Inadequate adaptability of the HPFH system with certain buildings is a challenge.** The installation of the outdoor unit of HPFH systems requires a large space; the limited reserved space of high-rise apartment buildings constrains the ability to install HPFH systems at these buildings. In addition, potential users are concerned about the complex installation and maintenance of the HPFH system. Furthermore, because outdoor air in the YRD region is relatively humid, the outdoor heat exchanger may frost during the operation of heat pumps, which may lead to problems such as decreasing heating capacity and unstable operation, negatively impacting users' experiences.

**Unsatisfactory heating comfort is the major challenge for mini-splits.** Although many of the mini-splits manufacturers have been developing more advanced products being able to provide higher indoor thermal comfort, the mainstream mini-split heat pump products on the YRD market still adopt a top-down air flow pattern in the heating mode, resulting in poor thermal comfort. Research shows that about 50% of mini-split users complain about the "slow heating process and poor heating performance" of the product.<sup>5</sup>

## Suggestions

### For users

**Get to know heat pumps and prioritize them over gas boilers as the home heating device.** HPFH systems can provide excellent indoor comfort in both summer and winter. HPFH systems' low operating cost also makes their whole-life cost close to or even lower than that of gas boilers. For mini-split products, with the improvement of the product, both the heating capacity and the heating comfort (through the adjustment of the air flow pattern) will be improved. These improvements, combined with lower cost and simpler purchase and installation, are making mini-splits a recommended choice for more home heating, especially for households that are sensitive to up-front investment and older residential buildings that are not suitable for HPFH system installation.

**Retrofit residential buildings to install heat pumps.** Older residential buildings may encounter difficulties in installing the outdoor units of HPFH systems, including insufficient space, unstable external walls, and low load-bearing capacity. To address these problems, households in older residential buildings may consider sharing a set of heat pump devices (similar to the centralized HVAC [heating, ventilation, air conditioning] systems in commercial buildings). These households can install the outdoor unit on the ground or rooftop in a way that does not affect the wall structure. Even in these cases, however, retrofits are needed to improve older residential buildings' insulation and thus reduce the overall heating demand, so that heat pumps with lower heat capacity and lower price could be installed.

### For policymakers

**Support heat pump manufacturers and retailers with subsidies.** Targeted subsidies are critical to narrowing the cost gap between heat pumps and other home heating devices. Subsidies at the production end can directly benefit heat pump manufacturers and boost heat pump industry development. Such subsidies can take various forms, including research and development subsidies, product subsidies, and tax credits.

**Accelerate policies that encourage or mandate the use of heat pumps for heating in new residential buildings.** Policies could mandate some aspects of the installation of home heating systems in new residential buildings, such as not encouraging the use of fossil fuel systems or requiring heat pumps. In a softer approach, policies could provide incentives to real estate development projects that choose to adopt heat pumps, such as relaxing restrictions on the salable floor area ratio.

**Incorporate heat pumps into the voluntary emissions reduction certification system.** Using heat pumps for heating and cooling offers great potential in carbon reductions. Monetizing the environmental attributes of heat pumps by permitting the issuance of China Certified Emission Reductions (CCER) for heat pump emissions reduction projects may help reduce heat pump costs.

**Improve public awareness of heat pumps.** At present, lack of public awareness of heat pumps is a major barrier to their growth. To increase the public awareness of heat pumps, relevant authorities, social organizations, and heat pump manufacturers need to work together. Publicizing the advantages of heat pumps, including user comfort, economic benefits, and positive environmental impacts, will help potential users realize that heat pumps are not only a comfortable and economical choice for heating, but also a key enabler of the national climate goals.

## For real estate developers

**Establish long-term cooperation with heat pump suppliers.** Through cooperation with heat pump manufacturers or retailers, real estate developers could simplify the purchase process of heat pumps, accelerating the scale of their adoption. Developers can also help connect users and heat pump suppliers with convenient access to heat pump product purchase and after-sales service, to attract more potential users.

**Develop "heat pump friendly" and "heat pump ready" homes.** During the project planning and design stages, developers should consider the conditions required for heat pump installation, such as setting aside a platform and space for the installation of outdoor units.

**Explore innovative business models to apportion the up-front cost of heat pumps.** In view of the high up-front investment of HPFH products, developers should explore innovative business models to help users apportion the early costs with approaches such as providing loans for the purchase of the whole system and receiving paybacks by charging heating fees and property fees.

## For manufacturers and retailers

**Optimize heat pump products customized specifically for the climate of the YRD region.** Due to the implementation of the "coal switch" policy in recent years, heat pump products developed for rural users in northern China have been the focus of many heat pump manufacturers. However, heat pump products for southern China residents need further improvement. Optimizations could be undertaken in the following areas:

- **Optimizing the heating function of mini-splits to improve heating comfort:** In view of the poor heating comfort of mini-splits, efforts could be made to optimize the air supply pattern, such as improving temperature distribution in the heating mode of wall-mounted mini-splits by increasing the volume of air supply and blowing air downward. Tower type air conditioners could also be optimized to develop a separated air supply pattern that blows cooling air from the top and heating air from the bottom.
- **Developing and promoting smaller HPFH systems for small and medium-sized apartments:** One of the main reasons for the high purchase cost of HPFH systems is the high nominal capacity of the mainstream heat pump products, which typically have a heat generation capacity above 10 kW. These products are suitable for larger apartments but are too large for the small and medium-sized apartments typical of the YRD region, resulting in many smaller homes being equipped with large HPFH systems and an unnecessary cost burden for users. Therefore, we suggest heat pump manufacturers design and promote products with a smaller capacity (nominal capacity below 8 kW with single-fan outdoor unit), which would be easier to install for small and medium-sized apartments.
- **Solving the frost problem caused by the high air humidity in the YRD region:** High outdoor air humidity may cause the problem of frost in the outdoor unit of the heat pump system, which will lead to lower heating performance and higher energy consumption, reducing heating comfort and increasing cost. This problem should be better addressed during the heat pump R&D process.

**Develop and promote multifunctional heat pumps able to provide cooling, heating, and domestic hot water.** In addition to the heating and cooling functions of HPFH systems, multifunctional products are able to provide domestic hot water. At present, users of HPFH systems need to install separate

domestic water heaters. In contrast, gas boilers usually have both heating and domestic hot water functions, which is one of the reasons users choose gas boilers rather than HPFH systems. Therefore, the development of multifunctional heat pumps will greatly increase the competitiveness of heat pumps. In addition, multifunctional heat pumps can further contribute to energy savings and emissions reductions via heat recovery devices in summer.

**Develop heat pumps with low-GWP refrigerants.**<sup>xv</sup> The heat transfer medium known as refrigerant is crucial for heat pump operation. A wide range of refrigerants with high GWP (e.g., R410a, R134a, etc.) has been extensively used in heat pump products, and would contribute to global warming if leaked. Shifting heat pumps toward low-GWP refrigerants (e.g., natural refrigerants including ammonia, carbon dioxide, etc.) would make heat pumps more environmental-friendly.

**Provide whole-system service for home heating system upgrades.** A whole-system approach means making envelopes more air-tight and improving the insulation alongside the equipment upgrade. With improved envelopes, the home heating demand can be reduced, further lowering the operation cost. And smaller heat pumps that are less expensive and easy-to-install can be applied.

**Disseminate and demonstrate successful installation and use of heat pumps.** At present, residents in the YRD region have limited chances to learn about heat pumps. Providing successful case studies of heat pump installation and use through cooperation with heat pump suppliers and developers would help increase awareness and confidence among potential customers.

xv Global warming potential (GWP) is the heat absorbed by any greenhouse gas in the atmosphere, as a multiple of the heat that would be absorbed by the same mass of carbon dioxide (CO<sub>2</sub>). GWP is 1 for CO<sub>2</sub>.

# Heat Pumps for China and Beyond

Heat pumps are considered a key technology for addressing global warming, and they have been widely used around the world because of their advantages of high energy efficiency and low emissions. Many countries are developing policy measures to accelerate the promotion and deployment of low-carbon home heating systems: in the European Union, the RePowerEU plan released in March 2022 proposed targets of (1) doubling annual sales, (2) adding 10 million heat pumps in the next five years, and (3) adding a total of 30 million heat pumps by 2030; in the United States, the Inflation Reduction Act signed in August 2022 proposed to encourage residents to purchase heat pumps for heating with significant rebates and tax incentives.

About 190 million heat pumps are currently used for space heating in buildings around the world, covering 10% of heating demand in the building sector, according to an International Energy Agency report, but the deployment rate of heat pumps is still short of that required by the 2050 net-zero carbon goal.<sup>9</sup> Further efforts are needed by all stakeholders to accelerate the adoption of heat pumps. The promotion of heat pumps for home heating in China's YRD region not only contributes to the zero-carbon heating in this region, but also accelerates the adoption of heat pumps globally to achieve zero-carbon heating on a larger scale.

## **Promoting zero-carbon home heating in other regions of China**

The zero-carbon transition of home heating by heat pumps in the YRD region can serve as a model for other southern regions of China, such as Hunan, Hubei, Sichuan, and Chongqing in the middle and lower reaches of the Yangtze River. Similar to the YRD region, these regions also have hot summers and cold winters, and rely on distributed devices for heating. These less-developed regions can learn from the promotion of heat pumps in the YRD region.

In northern China where heating demand is higher, low ambient temperature ASHPs have been adopted. For example, in rural areas of Beijing, Tianjin, and Hebei, heat pumps are the main device installed in the national program of the "coal switch" initiative supported by government subsidies. Government subsidies have been playing the central role in promoting heat pumps in these regions. As a result, the real market and the corresponding sales model for heat pumps haven't been fully established. In contrast, home heating systems used in the YRD region are mostly purchased by users themselves or real estate developers. The successful procurement models in this region could provide valuable experience for northern China.

## **Contributing to global zero-carbon home heating**

As the world's manufacturing powerhouse, China is also the world's largest exporter of ASHPs. In recent years, China's export of these products has experienced rapid growth, with export volume reaching 4.86 billion RMB (US\$721 million) in 2021, nearly quadruple the level of 2017.<sup>10</sup> In the pursuit of combating climate change, the demand for heat pumps is growing rapidly. In 2021, global heat pump sales grew by 13%, and the European heat pump market even reached a new record with 35% growth. In 2023, the energy crises in Europe due to the Russia-Ukraine conflict continued to further stimulate demand for heat pumps.

The demand for heat pumps will continue to increase for years, providing abundant space for the growth of China's heat pump exports. Therefore, the large-scale promotion of heat pumps in the YRD region will provide valuable market experience and user feedback for Chinese manufacturers, improving the competitiveness of Chinese heat pumps in the international market.

Around the world, there are many regions with subtropical humid climates similar to that of the YRD region (see Exhibit 19), and about 15% of the world's population lives in these regions. The valuable experience of promoting heat pumps for heating in the YRD region will provide a reference for residents in these regions and contribute significantly to the global zero-carbon home heating effort.

### Exhibit 19: Regions with climate similar to that of the YRD region



Source: Köppen climate classification

# Appendix A: Building Simulation Input Parameters

## Exhibit A1: Envelope parameters

Scenario	Typical building envelope	Energy code-compliant envelope <sup>11</sup>	Advanced building envelope
Heat transfer coefficient of external walls (W/m <sup>2</sup> -K)	1.14	0.6	0.53
Heat transfer coefficient of roof (W/m <sup>2</sup> -K)	0.93	0.4	0.48
Heat transfer coefficient of windows (W/m <sup>2</sup> -K)	2.8	2.5	1.71
Solar heat gain of external windows (W/m <sup>2</sup> -K) (SHGC)	0.75	0.67	0.67
Air tightness (ACH)	1	0.5	0.5

## Exhibit A2: Apartment parameters

Apartment size	Large	Small
Area (m <sup>2</sup> )	108	70
Apartment size	3 bedrooms + 2 living rooms + 2 bathrooms	2 bedrooms + 2 living rooms + 1 bathroom
Family members	Three-generation family (retired elderlies + working parents + child; 5 persons)	Typical family (working parents + child; 3 persons)
People in room on weekdays (Mon.–Fri.)	Living room: 08:00–12:00, 14:00–22:00 Bedroom 1: 12:00–14:00, 22:00–08:00 Bedroom 2: 22:00–08:00	Living room: 18:00–22:00 Bedroom: 22:00–8:00
People in room on weekends	Living room: 08:00–12:00, 14:00–22:00 Bedroom: 12:00–14:00, 22:00–08:00	Living room: 08:00–12:00, 14:00–23:00 Bedroom: 12:00–14:00, 23:00–08:00

# Appendix B: Concepts and Assumptions for Economic Analysis

## **Up-front purchase cost**

This includes the costs of purchasing and installing the heating system. Up-front purchase costs used in this study were collected from multiple sources, including manufacturers' online stores and interviews with manufacturers. For general home users, different heating systems are purchased in different ways. For example, mini-splits and electric resistance heaters can be purchased in manufacturers' online and offline stores, with installation service provided by manufacturers. For systems with more complicated installation, such as HPFH systems, gas boilers, and EFH, manufacturers normally arrange for local retailers to assist users in design, device selection, and installation.

The purchase costs of heating systems in scenarios other than HPFH and mini-splits also include the purchase costs of cooling systems. For these systems, the price of a home air conditioner (mini-splits) is used as the referential cost of the cooling system.

## **Operating cost**

This includes the cost of electricity or gas used for heating. For more detailed analysis, our study adopted the average peak–valley electricity price in the YRD region.<sup>12</sup> We also adopted the average civil gas price in 36 large and medium-sized cities across the country.<sup>13</sup> The operating costs of cooling are not included.

## **Maintenance cost**

This is the cost of repair, parts replacement, and device maintenance during the service life of the home heating system. The maintenance cost in this research was determined mainly through market surveys.

## **Salvage value**

Salvage value refers to the residual value of the home heating system at the end of its service life. Salvage values are considered only for devices with a service life longer than 10 years. For example, the service life of a floor heater system is generally 50 years. This research adopts the straight-line depreciation approach to calculating the amount of depreciation after 10 years of service and calculates the salvage value by subtracting the amount of depreciation from the purchase cost. The salvage value is expressed as a positive cash flow after 10 years.

# Endnotes

<sup>1</sup> International Energy Agency, Heating, 2022, <https://www.iea.org/reports/heating>.

<sup>2</sup> Yuan Zheng et al., "Developing Green-Building Design Strategies in the Yangtze River Delta, China, through a Coupling Relationship between Geomorphology and Climate," *Land*, 2022.

<sup>3</sup> Shan Hu et al., "A Survey on Energy Consumption and Energy Usage Behavior of Households and Residential Buildings in Urban China," *Energy and Buildings*, Vol. 148, pp. 366–378, 2017.

<sup>4</sup> US Energy Information Administration, "Residential Energy Consumption Survey," 2015, <https://www.eia.gov/consumption/residential/data/2015/>.

<sup>5</sup> Building Energy Conservation Research Center of Tsinghua University, "Annual Report on China Building Energy Efficiency," Beijing: China Architecture & Building Press, 2021.

<sup>6</sup> Stephanie Cernivec, "Answering Some of Electric Floor Heating's Most Frequently Asked Questions (FAQs)," 2018, <https://www.warmlyyours.com/en-US/posts/answering-some-of-electric-floorheating-s-most-frequently-asked-questions-faqs>.

<sup>7</sup> J. Hong et al., "Assessing Heat Pumps as Flexible Load," Proceedings of the Institution of Mechanical Engineers, Part A: *Journal of Power and Energy*, Vol. 227.1, 2013.

<sup>8</sup> Arthur Rinaldi et al., "What Adds More Flexibility? An Energy System Analysis of Storage, Demand-Side Response, Heating Electrification, and Distribution Reinforcement," *Renewable and Sustainable Energy Reviews*, Vol. 167, 2022.

<sup>9</sup> International Energy Agency, Heat Pumps, 2022, <https://www.iea.org/reports/heat-pumps>.

<sup>10</sup> China Heat Pump Association, "China Heat Pump Heating Annual Market Review," 2021.

<sup>11</sup> Ministry of Housing and Urban-Rural Development, "General Code for Energy Efficiency and Renewable Energy Application in Buildings," Beijing: China Architecture & Building Press, 2021.

<sup>12</sup> Source: State Grid app.

<sup>13</sup> Source: CEIC, Price Monitoring Center of National Development and Reform Commission.

Yihan Hao, Xinxin Hu, Ting Li, Guangxu Wang, Meng Wang, *Zero-Carbon Home Heating in China's Yangtze River Delta Region: Heat Pumps as a Core Solution*, RMI, 2023, <https://rmi.org/insight/zero-carbon-home-heating-in-chinas-yangtze-river-delta-region/>.

RMI values collaboration and aims to accelerate the energy transition through sharing knowledge and insights. We therefore allow interested parties to reference, share, and cite our work through the Creative Commons CC BY-SA 4.0 license. <https://creativecommons.org/licenses/by-sa/4.0/>



All images used are from iStock unless otherwise noted.



**RMI Innovation Center**

22830 Two Rivers Road  
Basalt, CO 81621

[www.rmi.org](http://www.rmi.org)

© January 2024 RMI. All rights reserved.  
Rocky Mountain Institute® and RMI® are  
registered trademarks.